

## CX3G PLC user manual

Thank you for choosing Coolmay CX3G series PLC. This manual mainly explains the features, general specifications and wiring methods of CX3G series. Detailed programming information please refer to <Coolmay CX3G PLC Programming Manual>.

Main features of CX3G series PLC.

- Highly integration. At most 40DI/40DO (digital type can be customized transistor, relay mixed), 16AI (analog input can be customized temperature, current, voltage or mixed) / 8AO (analog output can be customized current, voltage or mixed).
- Comes with 2 PLC programming ports: Mini typeB usb port (speed of reading and downloading is more faster) and RS 232 (8-hole mouse head female seat), normally have 2 RS 485 ports, both RS 232 and CAN are optional.
- Support multi-channels high-speed counting and high-speed pulse. High-speed counting normally single-phase 6 60KHz or AB(Z) phase 2 60KHz+ AB phase 1 10KHz. High-speed pulse normally Y0-Y3 each channel 100KHz, Y4-Y7 each channel 10KHz, acceleration and deceleration individually. The total amount of HSC and HSP output can not exceed 480KHz. CX3G-16MT, normally 8 channels 10KHz.
- Support special encryption. Setting 12345678 as password can thoroughly prevent the data from being read. (Attention: Only supports 8-bit password encryption)
- 32K steps of program capacity, 32K power-failed holding registers which support interrupting, linear arc interpolation and PID auto-tuning.
- Use 5.0mm pitch pluggable terminals for easy wiring; use DIN rail (35mm wide) and mounting holes for installing.
- DCX3G series is the same with CX3G, but without the body case, and performance is the same as CX3G.
- Super function. Compatible with FX3G/FX2U/FX3S series PLC, operation speed more fast.

### Products information:

◆ Name Rules CX3G - 48 M RT - 8AD 4DA - V - A0 - 1C1 - 1P - 485/232

- Series: CX3G: CX3G series plc
- I/O Points: 16 : 8DI/8DO 24 : 12DI/12DO 32 : 16DI/16DO 34 : 18DI/16DO 48 : 24DI/24DO 64 : 32DI/32DO 80 : 40DI/40DO
- Module: M: Main Module
- DO type: R: relay T: transistor RT: relay and transistor mixed
- AI: 0~16 channels are optional
- AO: 0~8 channels are optional
- AI type: E Thermocouple (can be customized K, T, S, J type)  
PT: Pt100 PT1000:PT1000 NTC:Thermal resistance (10K/50K/100K)  
A0:0-20mA A4: 4-20mA V:10-10V V5:0-5V V5:-5-5V V:-10V-10V
- AO type: A0:0-20mA A4: 4-20mA V:0-10V V5:0-5V V:-10-10V V5:-5-5V (Attention:negative voltage will occupies two channels DA)
- C1 stands for single phase high-speed counting, C2 for AB phase counting, C3 for ABZ counting. Normally single-phase 6 60KHz or AB (Z) phase 2 60KHz+ 1 10KHz.
- P stands for high-speed pulse; normally 8 channels, Y0-Y3 is 100KHz, Y4-Y7 is 10KHz. High-speed counting + high-speed pulse total output can not exceed 480KHz.
- COM port: refers to digram1: basic parameters

### ◆ Basic specification

Diagram1: basic parameters

CX3G series standard PLC	Digital value		Analog (optional)		COM Port	High-speed counting			High-speed pulse	Size				
	DI	DO	Max AI	Max AO		485/232/CAN	Single phase	AB phase		ABZ phase	Output	Dimension (MM)	Cutout size (MM)	
CX3G-16M	8	8	0	0	2 RS485 port are default can be customized 1 485, 1 232 Or 1 485, 1 CAN Or 1 232, 1 CAN Ethernet port is optional in 48M	Normally single phase 6 60KHz	Normally AB(Z) 2 60KHz+1 10KHz	Normally AB(Z) 2 60KHz+1 10KHz	Normally 8 channels Y0-Y3 100KHz, Y4-Y7 10KHz. High-speed counting + high-speed pulse total output can not exceed 480KHz.	65	90	36	57	99
CX3G-24M	12	12	6	4						130	90	36	122	99
CX3G-32M	16	16	2	0						200	90	36	192	99
CX3G-48M	24	24	8	4										
CX3G-34M	18	16	12	8										
CX3G-64M	32	32	16	8						290	90	36	282	99
CX3G-80M	40	40	4	4	CAN is optional									

MT is a transistor output: YO-Y3 is a MOS tube, others are transistors; MR is a relay output; MRT is a mixed output, which is optional according to customer requirements. (CX3G-16MT, Y0-Y7 are all transistors) CX3G-24M if it be customized 8 analog input, the maximum digital input is 10.

Diagram 2: electrical parameters

Electrical Parameters	
Input Voltage	DC24V
Digital Input Index	
Isolation Mode	Photocoupling
Input Impedance	High-speed input 3.3KΩ Common input 4.3KΩ

Input ON	Electric current of high-speed input is higher than 5.8mA/24V	Electric current of common input is Higher than 9.9mA/24V
Input OFF	Electric current of high-speed input is higher than 4.5mA/19V	Electric current of common input is Higher than 4mA/17V
Filter Function	With filter function, the filter time can be set amon 0-60ms, defaulted as 10ms	
High - speed Counting	Normally single phase 6 channels 60KHz or AB(Z) pahse 2 channels 60KHz+1. AB phase 1 channel 10KHz	
Vil	Passive NPN, Common Isolation, S/S connect 24V <sup>+</sup>	
Relay Output Index		
Max Current	2A/point, 4A/4 point COM, 5A/8 point COM.	
Load Voltage	Below DC30V/ Below AC220V	
Circuit Insulation	Relay Mechanical Insulation	
On Respond Time	About 10ms	
Mechanical Life (without load)	10 million times	
Electrical Life (rated load)	300 thousand times	
Vol	Normally open dry contact output, COM can be connected to positive or negative	
Transistor Output Index		
Max Current	MT: 0.5A/point, 0.8A/4point COM, 16A/8point COM; MOS tube: 2A/point, 4A/4point COM	
Load Voltage	DC24V	
Circuit Insulation	Optocoupler Insulation	
Isolation Voltage	1500VAC	
ON Respond Time	High-speed output: 10μs, and others 0.5ms	
High-speed Output Frequency	8 channels: Y0-Y3 is 100KHz, Y4-Y is 10KHz. High-speed counting and pulse can't over 480KHz, CX3G-16MT, normally 8 channels 10KHz.	
Vol	Low level NPN, COM connected to negative	
Analog Input Index		
Input Signal	PT100/PT1000/thermocouple/NTC/0-10V/0-5V/-5V-10V/0-20mA/4-20mA/ customizations.	
Respond Time	One scanning cycle	
AI Quantity	0-16 channels	
Accuracy	12bits	
Analog Output Index		
Output Signal	0-5V/0-10V/-10-10V/-5-5V/0-20mA/4-20mA/others can be customized	
AO Quantity	0-8 channels	
Accurary	12bits	
Interface		
Programming Port	Come with 2 programming ports: Mini TypeB (downloading operation speed faster) and RS232 (8-hole mouse head holder)	
COM port	Refers to (diagram 1: basic parameters)	
Environment		
Operating Temperature	0°C~50°C	
Relative Humidity	5%~95%RH	
Storage Temperature	-20°C~70°C	
Vibrational Frequency	10-57Hz, amplitude 0.035mm, 57Hz-150Hz, 4.9m/s <sup>2</sup> (10 times each on X, Y, Z, total 80 minutes each)	

### Mechanical Design Reference

#### ◆ Installation Size:

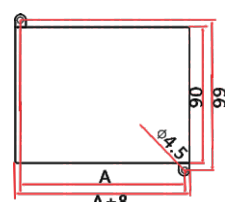

Cutout size: A\*99mm  
Dimension:(A+8)\*90mm

CX3G-16M	A:57mm
CX3G-32/22M	A:122mm
CX3G-48/34M	A:192mm
CX3G-64/80M	A:282mm

Diagram 1 Installation dimension drawing

### Electrical design reference

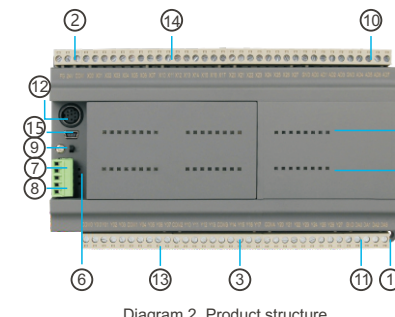

Diagram 2 Product structure

- Mounting hole
  - Terminal block for input signal of power supply
  - Terminal block of digital output
  - LED of Digital Input
  - LED of Digital Output
  - PWR: Power-up State RUN:The light is On when the PLC is run ERR: The indicator will flash when the program is wrong
  - RS485/RS232/CAN
  - RS485
  - RUN/STOP PLC operational switch
  - Analog input
  - Analog output
  - RS232
  - DIN-Rail Slot (35mm)
  - Terminal block of digital input
  - PLC USB programming port
- Note: CAN port location refer to Diagram 3 Hardware interface drawing and Diagram 5 Com port optional

#### ◆ Hardware Interface

0V 24V S/S X00~X07  
COM0 Y00~Y03 COM1 Y04~Y07  
**CX3G-16MT/MR/MRT**

0V 24V S/S X00~X7 X10 X11 X12 X13 AD0~AD2 GND AD3~ AD5  
COM0 Y00~Y03 COM1 Y04~Y07 COM2 Y10~Y13 GND DA0~DA3  
**CX3G-24MT/MR/MRT-6AD4DA**

0V 24V S/S X00~X17 GND0 AD0 GND0 AD1  
COM0 Y00~Y03 COM1 Y04~Y07 COM2 Y10~Y13 COM3 Y14 Y15 Y16 Y17  
**CX3G-32MT/MR/MRT-2AD**

0V 24V S/S X00~X07 X10~X17 X20~X27 GND0 AD0~AD3 GND0 AD4~AD7  
LAN COM0 Y00~Y03 COM1 Y04~Y07 COM2 Y10~Y13 COM3 Y14~Y17 COM4 Y20~Y27 GND DA0~DA3  
**CX3G-48MT/MR/MRT-8AD4DA**

0V 24V S/S X00~X07 X10~X17 X20~X27 X30~X37 GND0 AD0~AD3 GND0 AD4~AD7 GND0 AD8~AD11 GND0 AD12~AD15  
COM0 Y00~Y03 COM1 Y04~Y07 COM2 Y10~Y13 COM3 Y14~Y17 COM4 Y20~Y27 COM5 Y30~Y37 GND CAN-H CAN-L GND DA0 DA1 GND DA2 DA3 GND DA4~DA7  
**CX3G-64MT/MR/MRT-16AD8DA**

0V 24V S/S X00~X07 X10~X17 X20~X27 COM X30~X37 COM X40~X47 GND0 CAN-H CAN-L GND0 AD0 GND0 AD1 GND0 AD2 AD3  
COM0 Y00~Y03 COM1 Y04~Y07 COM2 Y10~Y13 COM3 Y14~Y17 COM4 Y20~Y27 COM5 Y30~Y37 COM6 Y40~Y47 GND DA0~DA3  
**CX3G-80MT/MR/MRT-4AD4DA**

Diagram 3 Hardware Interface Drawing

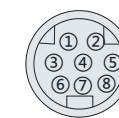

Diagram 4 PLC programming

#### 3G PLC PIN definition

Pin NO .	Signal	Description
4	RXD	Receive Data
5	TXD	Transmit Data
8	GND	Ground

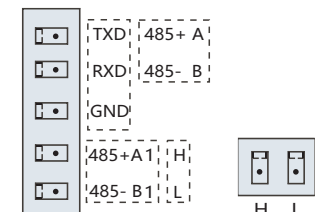

Diagram 5 com port optional

**Terminals wiring standard:** 22-14AWG wire. This series terminals are all pluggable terminals.

#### COM port definition:

Come with 2 programming ports: Mini type B usb port (more faster for downloading) and RS232 (8holes mouse head). 2 RS485 port are default, 34M/64M/80M can be customized 1 485 port and 1 232 port, CAN is optional, 16M/24M/32M/48M can be customized as 1 485, 1 232 or 1 485, 1 CAN or 1 232, 1 CAN Ethernet port is optional in 34M/48M/64M/80M

#### COM port explanation:

Serial 1: RS232 (PLC programming port); support Mitsubishi programming port protocol, which can be used for downloading PLC software and can be communicated with device that supports Mitsubishi porgramming protocol. Serial 2: RS485 (AB port/); support Mitsubishi programming port protocol, Mitsubishi BD board protocol, RS protocol and MODBUS RTU protocol Supports RS, RS2, WR3A, RD3A, ADPRW instructions

Serial 3: RS485 (A1 B1): 1. supports Mitsubishi programming port protocol, RS2 protocol and MODBUS RTU protocol. Supports RS2, WR3A, RD3A, ADPRW instructions CAN com port: supports RS2 and MODBUS RTU protocol Supports RS2, WR3A, DR3A, ADPRW instructions Net communication: Support Modbus TCP/UDP instruction Support, WR3A, RD3A, ADPRW instructions

Attention: Detail refers to <Coolmay CX3G&FX3GC programming manual>

## Equivalent Circuit

The PLC input (X) is an externally powered DC24V sink type (passive NPN) with the input signal isolated from the power supply. When using, connect S/S to 24V positive external power supply.

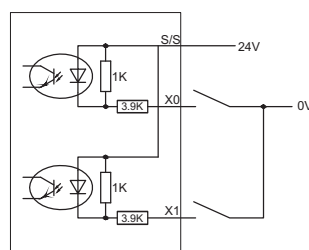

Diagram 6 Input wiring diagram

**PLC Digital Input Wiring:**  
 Port short circuit: The S/S of the PLC input terminal is connected to 24V, and the X terminal is connected to the power supply 0V, that is, the input has a signal;  
 Two-wire system (magnetic control switch): PLC switch input is connected to a two-wire magnetic control switch, the positive pole of the magnetic control switch is connected to the X terminal, and the negative pole is connected to 0V;  
 Three-wire system (photoelectric sensor or encoder): The PLC switch is connected to the three-wire photoelectric sensor or encoder. The power supply of the sensor or encoder is connected to the positive pole of the power supply, and the signal line is connected to the X terminal. The encoder and photoelectric sensor requirements are NPN type (PNP needs to be customized)  
**PLC Digital Output Wiring:**  
 Transistor: The output is NPN, COM is connected to the negative pole, and Y is connected to the positive pole of the power supply after the load.  
 Relay: dry contact output, COM can be connected to positive or negative

Diagram 7 shows the equivalent circuit diagram of the relay output module. The output terminals are several groups. Each group is electrically isolated. Different groups of output contacts are connected to different power circuits.

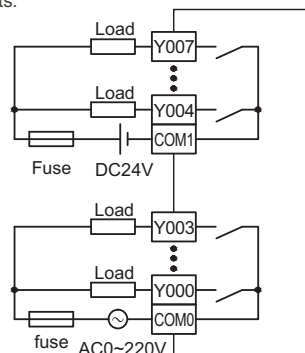

Diagram 7 Relay output equivalent circuit

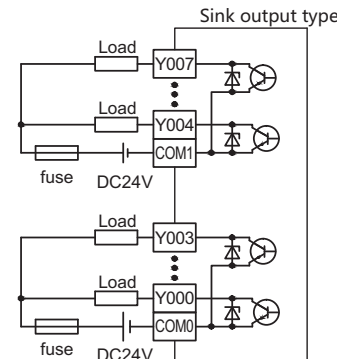

Diagram 8 Transistor output equivalent circuit

The equivalent circuit of the PLC output part of the transistor output type is shown in Diagram 8. Also known from the diagram, the output terminals are several groups, each group is electrically isolated, and different groups of output contacts can be connected to different power circuits; the transistor output stage can only be used for DC 24V load circuits. Output wiring is NPN, COM common cathode.

For the inductive load connected to the AC circuit, the external circuit should consider the RC transient voltage absorption circuit; corresponding to the inductive load of the DC loop, consider adding a freewheeling diode, as shown in Diagram 9.

Stepping or servo motor wiring as shown in Diagram 10, 3G series PLC default Y0~Y7 is pulse point, direction can be customized

Note: 5V drive must be connected to a 2KΩ resistor on DC24V

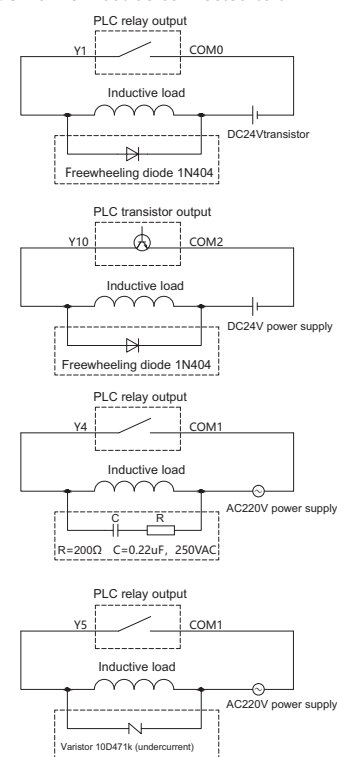

Diagram 9 Inductive load absorption circuit schematic

⊗ Note: All internal circuits in the illustrations are for reference only.

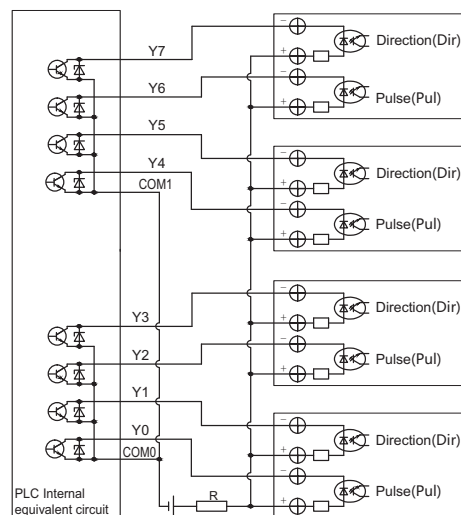

Diagram 10 Pulse output wiring diagram

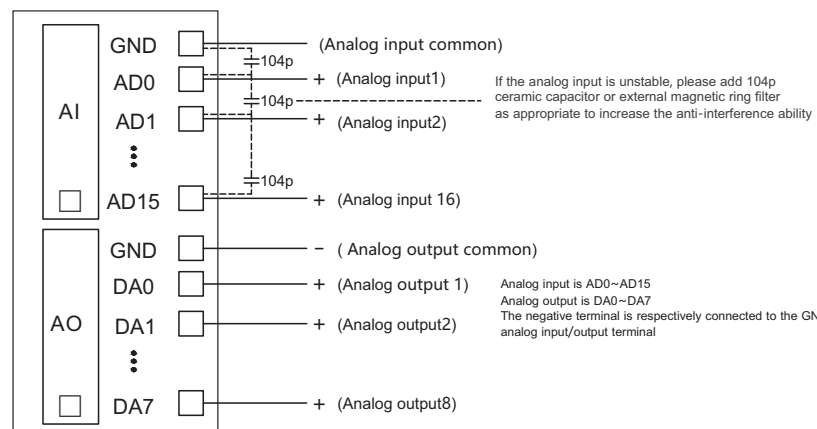

Diagram 11 PLC analog wiring

## PLC analog wiring

Two-wire system: the positive pole of the power supply is connected to the positive pole of the transmitter; the negative pole of the transmitter is connected to the AD side; the negative pole of power supply is connected to GND, which normally it is a wiring way of 4-20mA/0-20mA transmitter  
 Three-wire system: the positive pole of the power supply is connected to the positive pole of the transmitter, the negative pole of the power supply and the negative pole of the signal output are the same terminal and the transmitter signal output is connected to the AD terminal;  
 Four-wire system: the positive and negative poles of the power supply are respectively connected to the positive and negative poles of the transmitter, and the positive and negative poles of the transmitter signal output are respectively connected to the AD and GND terminals;  
 The analog line of temperature is connected to the AD terminal and the GND terminal respectively. If it is a three-wire Pt100, it needs to be connected in two lines. The GND common terminal of the analog input and output can be shared.

## PLC anti-interference processing

- Strong and weak currents should be separated and wired, and not common ground; when there is strong electric interference, magnetic rings should be added on the power supply side; and properly and effectively grounded according to the type of the chassis.
- When the analog quantity is disturbed, 104 ceramic capacitors can be added for filtering, and a correct and effective grounding can be performed.

## Programming Reference

### ◆ Devices Distribution and Statement of Power-down Save

	CX3G-16M	CX3G-24M	CX3G-32M	CX3G-34M	CX3G-48M	CX3G-64M	CX3G-80M
Digital input X	X00~X07 8 point	X00~X13 12 point	X00~X17 16 point	X00~X21 18 point	X00~X27 24 point	X00~X37 32 point	X00~X47 40 point
Digital output Y	Y00~Y07 8 point	Y00~Y13 12 point	Y00~Y17 16 point	Y00~Y17 16 point	Y00~Y27 24 point	Y00~Y37 32 point	Y00~Y47 40 point

Auxiliary Relay M	[M0~M383]384 point general/[M384~M1535]1152 point holding/[M1536~M7679]6144 point general/[M8000~M8511]512 point special
State S	[S0~S9]10point Initial state/[S10~S999]990point holding/[S1000~S4095]3096point general
Timer T	[T0~T199]200point 100ms general/[T200~T255]6point 100ms general/[T246~T249]4point 1ms grand total keep state/[T256~T319]64point 1ms grand total keep state/[T200~T245]46point 10ms general
Counter C	16bit up counter      32bit up and down counter      High-speed counter
Data Register D	[D0~D127]128point general      [D128~D7999]7872point Holding      [D8000~D8511]512point special
Data Register V, Z	[V0~V7] [Z0~Z7] 16point Indexing
Extended file register R	[R0~R22999]23000points support power outage/[R23000~R23999]1000points Internal use
Pointer JUMP, CALL branch	[P0~P255]256points/[P0~P1280]1281points (26232 version or above)
Nested Pointer	[N0~N7] 8point
Interruption	[I0□□~I5□□]6 points input interruption/[I6□□~I8□□]3points Timer interruption/[I010~I060]6points Counter interruption
Constant	K      16bit -32,768~32,767      32bit -2,147,483,648~2,147,483,647
	H      16 bits 0-FFFFH      32 bits 0-FFFFFFFFH

◆ Analog input register(AD means analog input, precision is 12 bit); supports FROM instructions or register direct assignment operation

FROM instruction can read directly:FROM K0 K0 D400 K16 reads 16 channel analog input.  
 Register read directly: D[8030]~D[8045] is the input value corresponding to the analog quantity [AD0~AD15]. The constant scan time is changed to D8059, which is started by M8039 (this function is available on version 26232). When the analog input has thermocouple type, you can only do up to 15 channels, of which AD4 (D8034) is the ambient temperature of the thermocouple. You can do 16 channels without the thermocouple type. Analog input range and corresponding values of registers can be refers to "Coolmay CX3G&FX3GC series PLC programming manual"  
 The temperature type is one after the decimal point is reserved, like 182.°C=18.2  
 Sampling of analog inputs

The number of filtering cycles = (R23600 ~ R23615) \* PLC scan time, the default is 100, the data can not be less than or equal to 0. If RS23600 = 1, a PLC scan cycle is sampled once, and the first analog input is changed once. The larger the value of R23600~R23615 is set, the more stable the result is.  
 D8073 is the smoothing filter coefficient of all analog inputs. Setting range: 0~999

Analog output register(DA means analog output, accuracy is 12 digits)Support TO instruction or registerdirect assignment operation

TO instruction direct output:T0 K0 K0 D500 K8, 8 channels analog

Register direct assignment operation:D[8050]~D[8057] corresponding to the analog output value of [DA0~DA7]

Which optional two-way DA is used when the negative voltage output is selected, the set value

range is as follows:

Serial Number	Register address	Setting range	Output type
DA0	D8050	0-4000	When D8058.0~D8058.7=0 Type is 0~20mA;
DA1	D8051	0-4000	
DA2	D8052	0-4000	
DA3	D8053	0-4000	
DA4	D8054	0-4000	When D8058.0~D8058.7=1 Type is 4~20mA.
DA5	D8055	0-4000	
DA6	D8056	0-4000	
DA7	D8057	0-4000	

The CX3G PLC's device power-off maintenance is permanently maintained, that is, all the devices in the holding area are not lost after the module is powered off.  
 The real-time clock uses a rechargeable battery to ensure that the clock is the current time. All power-off hold functions must ensure DC 24V.The voltage after the source is loaded is 23V or more, and the PLC power-on time is longer than 2 minutes, otherwise the power-off function will be abnormal.

Programming software: compatible with programming software GX8.86Q and GX WORKS2  
 Detailed materials please refer to <Coolmay PLC programming manual >  
 <CX3G PLC user manual> <FX3GX PLC user manual>

## TIPS

## CX3G PLC User Manual

— Before using this product, please read the relevant manual  
 Carefully use the product under the environmental conditions specified in the manual.

- In case of damaging the product, please confirm power supply range first (the regular power supply only limited to 24V DC, we suggest you to use the power supply which output voltage is 18W or higher than 18W), and wiring correctly, then electrify it.
- Before installing the product, please tighten the screw and clamp guide to avoid falling.
- Please do not wiring or plug cable when the power is on, otherwise it may cause electric shock or circuit damage. Disconnect the power switch immediately when the product smells or sounds abnormal. Do not drop metal shavings and wire tips into the control vent holes during screwing hole and wiring, which may cause product malfunctions and faults.
- Please do not tie the power cord and communication cable together or let them too close, you should keep them for more than 10cm distance. The strong and weak electricity should be separated and properly grounded. If the interference is serious the communication and high frequency signal input and output cables should be the shielded cables to improve anti-jamming performance.
- The digital input is an externally powered DC24V leakage type (passive NPN) with the input signal isolated from the power supply. When using, connect S/S to 24V positive external power supply.
- The COM of the binary input / output (transistor) is common to the cathode.
- Do not disassemble the product or modify the wiring optionally. Otherwise it may cause fault, malfunction, loss, or fire.
- Please make sure to turn off the all power when you install or dismantle the product, otherwise it may cause malfunction or fault.

## Catalog

Shenzhen Coolmay Technology Co., Ltd  
 Tel.: 0755-86950416-843  
 86960332-843  
 26051858-843  
 26400661-843

QQ:1687435500  
 Email: m3@coolmay.com  
 Website: www.coolmay.net  
 Version: 2021/05

Warm Tips.....	01
Product Features.....	02
Product informati.....	03
Electrical parameter.....	04
Mechanical design reference.....	05
Electrical Design Reference.....	06
Equivalent Circuit.....	07
Analog wiring.....	08
Anti-jamming treatmet.....	09
Programming Reference.....	10
Information Reference.....	11